

The Development and Design of Bronze Ordnance,
Sixteenth through Nineteenth Centuries

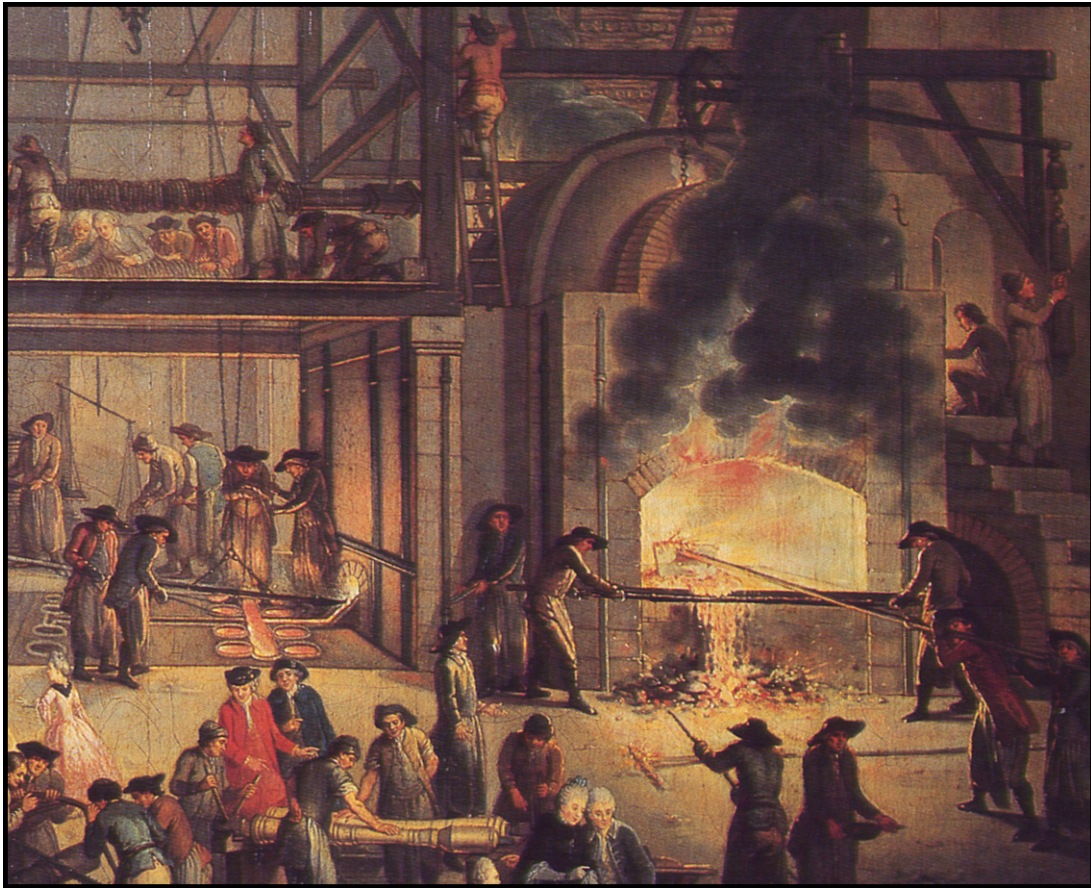

by

Chuck Meide

The College of William & Mary

November 2002

**The Development and Design of Bronze Ordnance,
Sixteenth through Nineteenth Centuries**

Introduction	1
Evolution, 16th-19th Centuries	1
Typology	1
Bronze vs. Iron	8
Decline of Bronze Ordnance	10
Morphology	13
Nomenclature	13
Decoration	25
Composition	30
Conclusion	31
References	33

Introduction

“Ordnance is the most accurate and acceptable generic term which embraces all those weapons of war which use an explosive charge to propel a missile in the direction of the enemy, and which are larger than those which can be used as personal arms” (Hughes 1969: 1). The technical development and unreserved application of cannon (a term which in its modern sense encompasses all of the types mentioned below) played a key role in European expansion and colonial hegemony (cf. Cipolla 1965). Ordnance remains, therefore, of great interest to archaeologists studying this process, or that of technological change in general. In addition, ordnance—and especially bronze as opposed to iron pieces—usually proves the most diagnostic artifacts found on a shipwreck or military site. This study is an overview of the history of the development, design, and manufacture of bronze muzzle-loading ordnance, which were widely used by the world’s military forces from the 16th to mid-19th centuries. Discussion is limited for the most part to guns (what are usually termed cannon), but also to mortars, howitzers, and to a lesser degree types such as the carronade and swivel gun.

Evolution, 16th-19th Centuries

Typology

Cannon of the 16th century inherited a medieval system of naming and classification. This traditional nomenclature was complex, imprecise, and often confusing, especially considering the wide range of calibers and lengths extant in the period before standardization (i.e., pre-18th century). For example, in the Tudor period alone there were at least twelve types of culverin (large, small, ordinary, extraordinary, bastard, special, etc.), five types of demi-cannon, five types of saker, and a multitude of others, often with exotic or zoomorphic names such as falcons, robinets, pellicans, sparrows, basilisks, lizards, fowlers, minions, murderers and double-murderers, serpentines, drakes (dragons), syrens, apostles, and even shrimps (cf. Carpenter 1993: 9-11). Most of these were made of bronze.

Despite the complex terminology and diverse range of sizes, the basic classification of muzzle-loading ordnance in the 16th and 17th centuries was essentially quite simple. The four main categories—the culverin, the cannon, the perrier, and the mortar—were based on the ratio of caliber to length (Lewis 1961: 18-37). These four basic types are illustrated in Figure 1. The longest guns, with a 32 to 34 caliber to bore ratio (sometimes as high as 40 or more), were called culverins. The culverin class covered a wide range of calibers (from 1½” to 5½”) and included the culverin itself (which fired an 18 pound shot) as well as demi-culverins (9 pound shot), sakers (4¾ to 7-pounder in late 1500s, and 5¼-pdr thereafter) (Figure 2), minions (4-pdr), falcons (2½ to 3-pdr), falconets (1¼ to

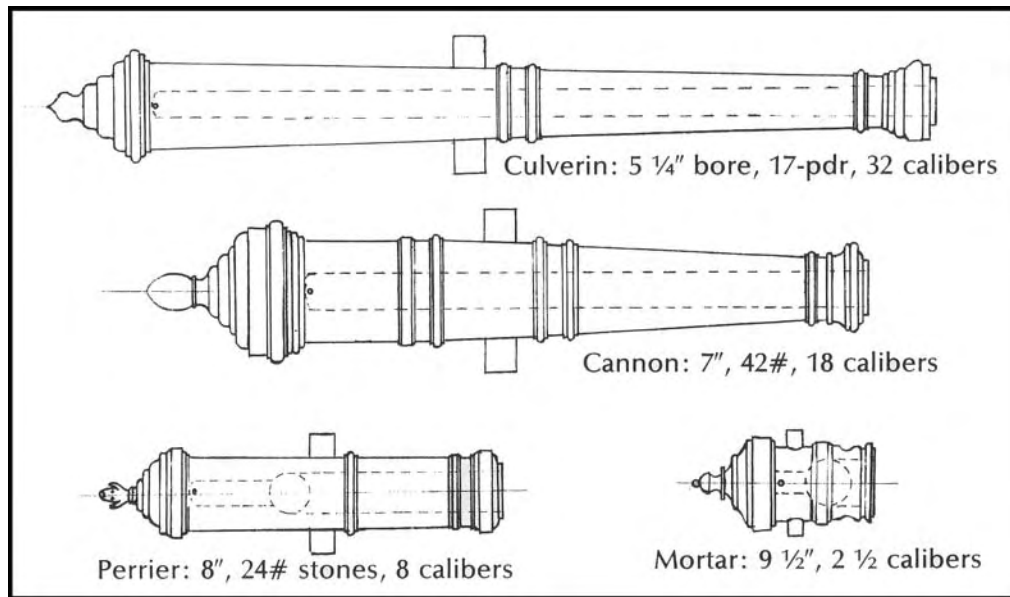

Figure 1. Four basic types of 16th century ordnance. From Tucker 1989: Figure 5, adapted from Lewis 1961: 38, in turn re-drawn from Lucar's 1588 English translation of Nicholas Tartaglia's *Three Books of Colloquies concerning the Art of Shooting in great and small pieces of Artillery*, published in Italy in 1537.

1½-pdr), and robinets (<1-pdr). The long barrel of the culverin family was designed for great range and accuracy, and they were used on both ships and (the smaller types) as field artillery (Lavery 1987: 97, 100-103; Gardiner 1979: 338).

The next longest type, the cannon proper, or “cannon of battery,” were relatively short-barreled (15 to 28 calibers long), large-bored, low velocity guns that fired heavy (usually 10 pounds or more, up to 60) missiles. Originally intended as battering pieces in fortifications, they were rare on ships until around 1650, though after that point they became rapidly became the standard naval weapon (Lavery 1987: 97). Subdivisions included the cannon-royal, cannon-of-seven (42-pdr), cannon (40-pdr), demi-cannon (the 32-pdr, which would become the universal lower-deck ordnance of British ships of the line by 1750), and, in the Spanish services, the thirds-of-cannon (*tercias*) and quarter-cannon (Tucker 1989: 11). Lighter versions were used as siege artillery in the land service. A well-preserved example of a full cannon is the bronze siege gun (*cañón de batir*) recovered from the Spanish Armada ship *La Trinidad Valencera* off the coast of Donegal and pictured in Figure 3.

The next group were the short and stubby perriers, which usually measured between 6 and 8 calibers in length. The perrier had a relatively large bore, and fired a heavy shot at a low velocity (Tucker 1989: 11). As the name implies, these pieces were originally intended to fire stone shots (which tended to shatter on impact) though by 1600 iron shot were the norm. Some perrier were breech-loaders. They were comparatively rare, though the Royal Navy did utilize a few on their largest ships in the first half of the 17th century (Lavery 1987: 97). The 24½-pdr cannon-perrier was the largest member of this

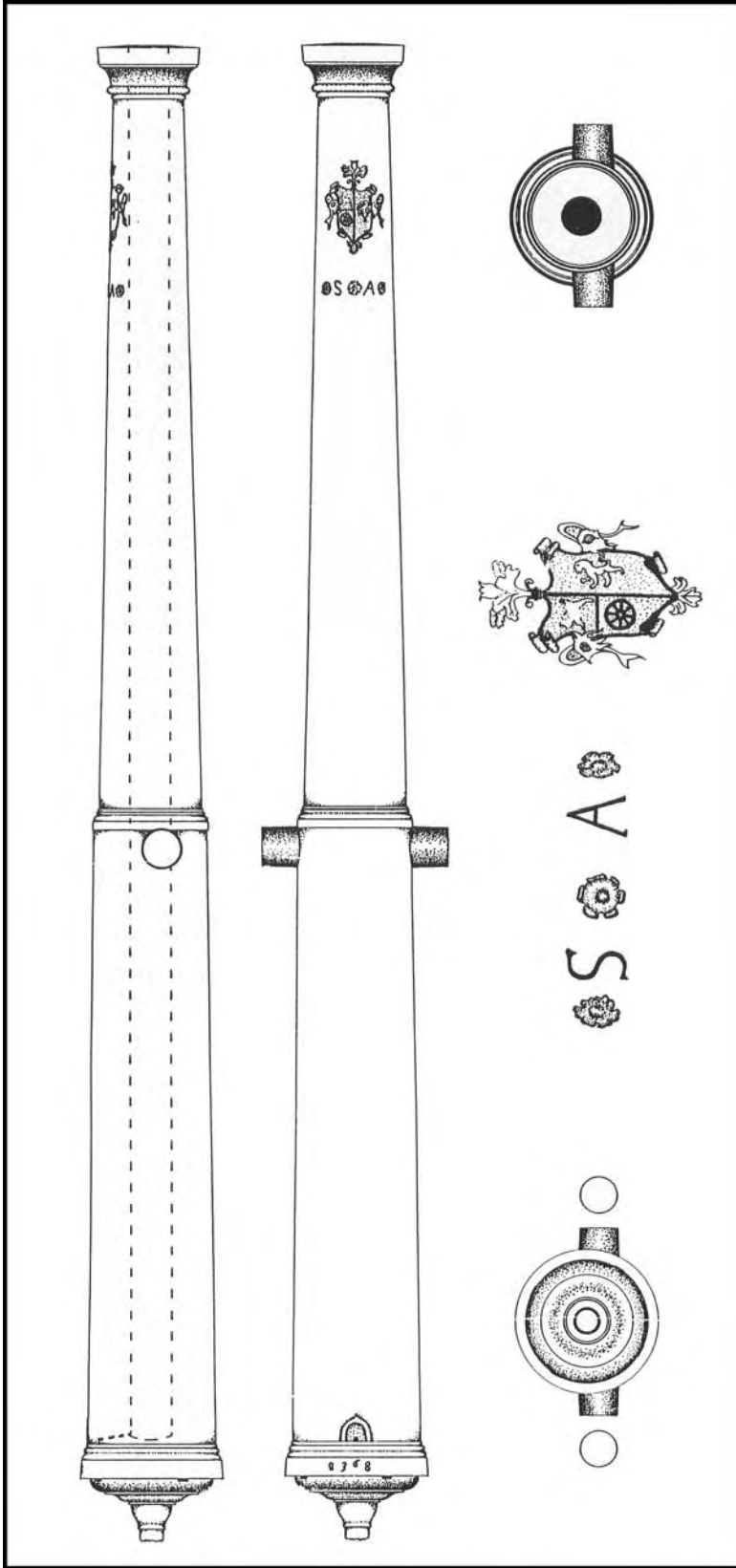

Figure 2. Italian bronze saker, ca. mid-16th century, recovered from the Church Rock site off Teignmouth, Devon, U.K., in 1976. It is approximately 10 feet long with a 3 1/2 inch bore, and a very rare example of a gun cast by the famed Alberghetti family (in this case, Sigismondo Alberghetti II) of Venice and Turin, probably sometime between 1539 and 1610. Note the tip of the cascable or button has broken off. Drawing by Rudi Roth, from Carpenter 1993: Plate 156.

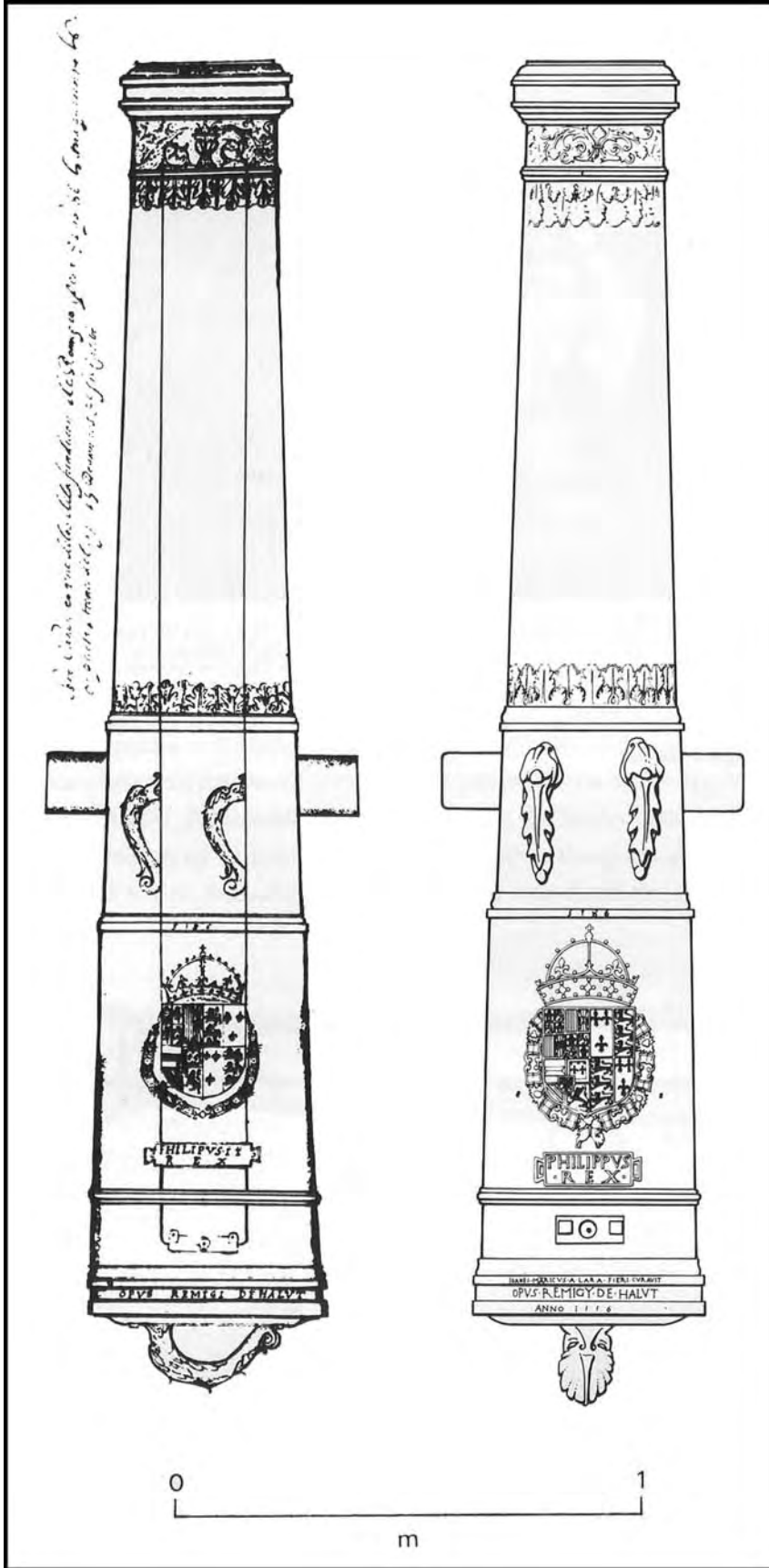

Figure 3. Bronze siege cannon (*cañón de batir*, or cannon of battery) recovered from the Spanish Armada invasion ship *La Trinidad Valencera*, lost off the coast of Donegal, Northern Ireland, in 1588. At right is an archaeological drawing of the recovered gun, on the left is a rare example of 16th century technical drawing, a scaled diagram of the exact gun (identified by weight marks) by Remigy de Halut of Malines in 1587. The coat of arms are of Phillip II of Spain (as King of England!) and the inscription reads *IONES.MARICUS.A.LARA.FIERI.CURAVIT/OPUS.REMIGY.ED.HALUT/ANNO 1556* (“Made on the instructions of Juan Manrique de Lara by Remigy de Halut in 1556”). The 40-pdr has a caliber of 183 mm, weighs 5186 Castilian pounds (2904 kg), and is 2.90 m in length. While intended for a land siege of London, it was probably deployed as shipboard ordnance as well. Martin 1997: 5.



Figure 4. A bronze 15-inch mortar cast in 1724 in Barcelona, captured by U.S. forces in 1898 during the Spanish-American War, and now mounted on a replica bed at the *Castillo de San Marcos* National Monument in St. Augustine, Florida. Maximum range is listed as 2100 yards or 1.2 miles. Photograph by the author.

family, and smaller pieces included port-pieces, slings, and fowlers. All of the perriers became obsolete by the mid-17th century, though similarly-stubby howitzers and carronades would take their place.

The final class, mortars, were the shortest of the muzzle-loaders at $1\frac{1}{2}$ to 3 calibers in length (Lewis 1961: 36-37). The direct descendants of large-bore medieval bombardars, mortars were large-caliber, low velocity artillery designed to fire the largest and heaviest projectiles at the highest possible trajectories, in order to drop them on targets from above (Figure 4). Because of this they were most commonly used as siege weapons, though occasionally small versions were used as field artillery (McConnell 1988: 113). They were not normally used in ship-to-ship engagements, though as early as 1682 specialized vessels called bombs or bomb ketches were mounted with (usually two) large mortars in order to bombard coastal defenses or towns (Ware 1992: 89-94). Mortars made of brass were used on both land and sea from the 16th through the 19th centuries, though iron mortars were more common in the latter century (McConnell 1988: 113-135).

By the mid- to late-17th century the various types of ordnance began to become standardized in terms of caliber and nomenclature, so that they could be referred to by the

weight of the shot they fired: 6-pdrs (pounders), 9-pdrs, 12-pdrs, 18-pdrs, 24-pdrs, etc. England was among the last to abandon the old naming system, as noted in Povey's *Sea Gunner's Companion* in 1702: "[A]ll countries but England name their guns by the weight of shot; which I think very proper" (Lavery 1987: 97). Though there was no universal system of caliber sizes, those adapted by various countries were more or less parallel (the British 32-pdr was considered the equivalent of the French 36-pdr, which fired shot weighing 14.53 kg and 17.60 kg respectively; these were the standard size cannon on the lower deck of each nation's 74-gun ships). In addition to lowering the overall number of different calibers, the new system resulted in "general purpose" guns, where the weight and length could be varied without changing the essential proportions or principles of construction (Gardiner 1979: 339).

A few new types of ordnance were developed in the 18th century, most notably the howitzer and carronade. The howitzer was basically a cross between the cannon and mortar; it could fire large shells at a medium to high trajectory (Tucker 1989: 109-110; McConnell 1988: 137-155). At about 5 to 10 calibers in length, howitzers were shorter than cannon but longer than mortars (Figure 5). While they could not fire at as high an angle as mortars, they were lighter and could be mounted on a carriage, greatly increasing their mobility. And though their shorter barrels meant a shorter range than cannon, their carriages allowed greater elevation, so they could fire larger shells over obstacles or the heads of friendly troops in order to reach their target. The first examples, Coehorn howitzers, appeared as early as 1728 and were widespread by 1750 (Hughes 1969: 39). Virtually all howitzers made before the early 1800s were cast of bronze. Following the Napoleonic wars, iron siege howitzers were introduced, though field pieces continued to be made of bronze (McConnell 1988: 137). Howitzers were never widely used at sea, especially after the introduction of the carronade, whose attributes made it extremely effective for close ship-to-ship action.

Carronades were similar to howitzers in that they were rather short, light, and had large bores in relation to their weight (Lavery 1987: 104-109; McConnell 1988: 103-111). Unlike the howitzer, carronades were used mainly to fire solid shot on a horizontal trajectory, and their specialized powder chambers allowed for thinner barrel walls. Because of their shorter barrels, they also had a short range, but their advantage laid in the fact that, due to their reduction in weight, they could fire a ball four times heavier than that of a cannon of equal weight. This highly successful naval weapon was introduced by the Carron Iron Company in Scotland in 1778, and was rapidly adapted as a standard ordnance by the Royal Navy. While there are a few examples cast in bronze (such as those illustrated in Figure 6), for the very most part carronades were produced of cast-iron (Carpenter 1993: 20).

A final type of ordnance not yet discussed is the swivel gun. These were small, one-man, anti-personnel cannon mounted on a swivel yoke bracket (usually placed on the gunwale of a ship) are believed by Lavery (1987: 103) to derive from the smallest of the perriers, the sling. Often breech-loading and quite frequently made of wrought-iron (especially in the 16th century), there were bronze examples of both muzzle- and breech-loaders throughout the period of study. Bronze swivel guns persisted in the 18th century French

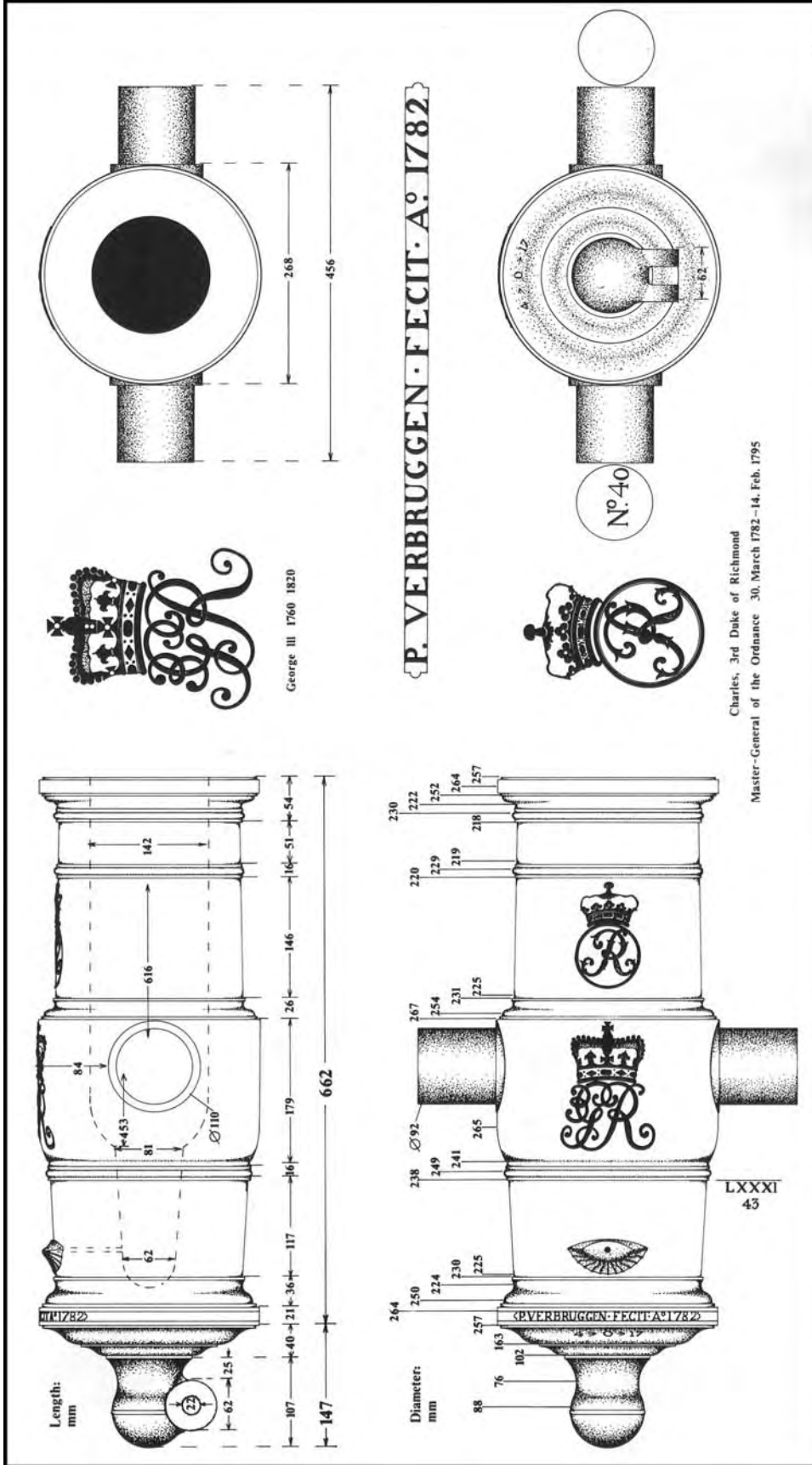

Figure 5. Light 5 1/2 inch howitzer, cast by the famed Verbruggen family at the Royal Brass Foundry in Woolwich in 1782. Now at the Museum of Artillery Rotunda, Woolwich. Cast in great numbers, this piece measures 2' 2" (66.04 cm) and weighs 4 1/8 hundredweight (462 lbs or 209.75 kg). Drawn by Rudi Roth, from de Beer 1991: 228.

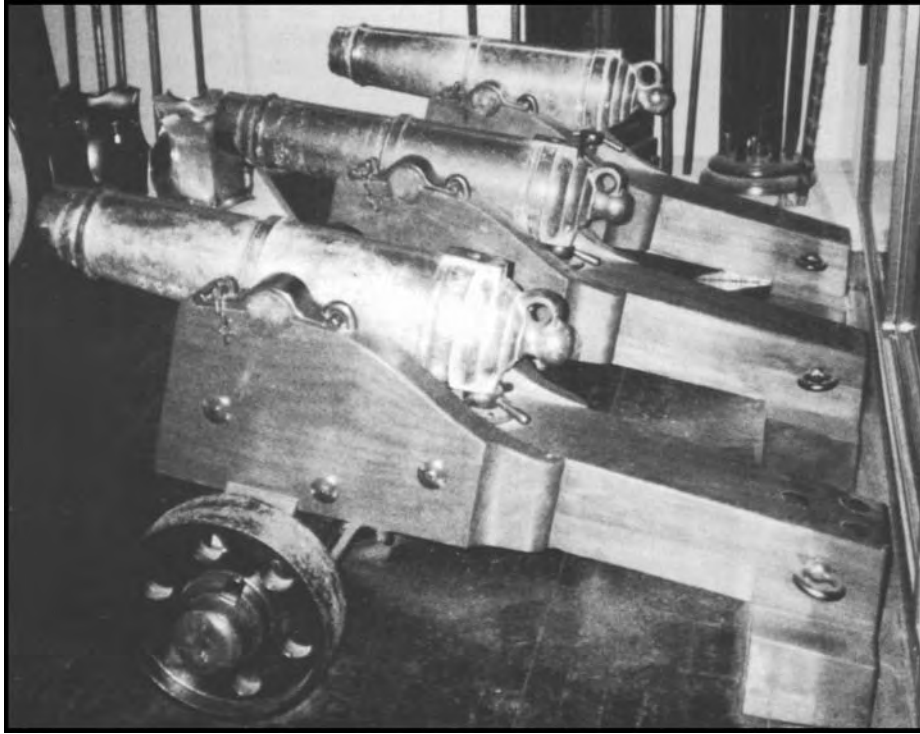

Figure 6. Rare examples of early 19th century bronze carronades, ca. 1820-1830, mounted on wooden garrison carriages. From Carpenter 1993: Plate 22.

navy even after the complete abandonment all other iron ordnance; the lighter weight of bronze swivels would have facilitated their movement from the ship's rail up into the tops or down into the ship's boats. The French ones circa 1780 looked like miniature undecorated bronze cannon, were three French feet (97.5 cm) in length and 174 French pounds (85 kg), and fired one pound (0.49 kg) shot (Boudriot 1986: 174). To a certain degree, especially on boats, the swivel gun was superseded by the more effective anti-personnel carronade, but ½-pdr iron muzzle-loaders remained in use on British ships through 1815 (Lavery 1987: 104).

Bronze vs. Iron

Writing at the end of the muzzle-loader era, British artillery officer Manley Dixon in 1858 summed up nicely the required material qualities necessary to create ordnance:

The material should be hard, so as not to yield too easily to the action of the ball when passing out of the bore; tenacious, so as to resist the explosive power of the Gunpowder and not to burst; and lastly, elastic, so that the particles of the material of which the Gun is composed should, after the vibration caused by the discharge, return to their original position (McConnell 1988: 15).

Bronze and iron were the only two metals with these requisite qualities available to historic gunfounders, and bronze was long considered the superior metal for ordnance manufacture. Up until the third quarter of the sixteenth century, however, iron guns outnumbered bronze pieces, though the former were almost all wrought iron, of decidedly inferior quality. The most powerful guns had to be cast, not hand-wrought, and as cast iron guns were overly heavy or dangerously unreliable, bronze was the material of choice throughout the 16th century. Though Henry VIII's *Mary Rose* (wrecked in 1545) displayed a marked diversity of bronze and iron ordnance (Guilmartin 1994: 148) by 1569 the decision was made to equip Queen Elizabeth's navy entirely with cast bronze guns (Lavery 1987: 84).

The main disadvantage of bronze guns was their price, which was generally three to four times higher than iron guns (Cipolla 1965: 42). In 1570 England, iron ordnance cost £10 to £20 per ton while bronze cost £40 to £60. With improvements in iron casting techniques, the price of iron began to fall by the turn of the century, and the difference in cost began to steadily increase, so that by 1670 iron cost only £18 per ton, while bronze cost £150 for the same amount (Lavery 1987: 84). As the principle maritime powers continued to increase the size of their navies in the 17th century, this cost became prohibitively expensive. An example, to put this greater cost in perspective: the four small bronze cannons carried as cargo on the French ship *La Belle* (wrecked in Matagorda Bay, Texas in 1686) cost more to manufacture than did the entire vessel! (personal communication, John de Bry, 1996)

Not surprisingly, rulers in the first half of the 17th century began to mandate and subsidize experimentation in iron gunfounding, in order to improve the quality of iron ordnance. Other than expense, however, bronze guns were still superior to iron ones in almost every way. Bronze was stronger, withstood the shock of discharge better, and lasted longer at sea. Bronze also was easier to cast, could be re-cast, and could be easily embellished with decoration. Because of this last quality, along with their hefty price tag, bronze guns also served as status symbols, an aspect whose importance should not be overlooked in the 17th century, when capital ships represented not only the might but the prestige of the king.

Despite the fact that bronze is 20% heavier than iron, bronze guns were lighter than their counterparts because the stronger metal could be used to make thinner guns of the same caliber (Tucker 1989: 10). The dramatic weight differences between bronze and iron guns of the same caliber are illustrated in Table 1 (keeping in mind that a gun of the same size and metal could vary by as much as 2-3 hundredweight or 224-336 lbs) (Tucker 1989: 10). The reduced weight of bronze ordnance was particularly important for field artillery.

One especially salient advantage was that bronze guns were less likely to break while firing, and when they did the barrel usually bulged or split open longitudinally at the breech rather than explode. When iron cannon burst they tended to shatter and fly to pieces, which caused much more catastrophic damage to nearby personnel (Tucker 1989: 10; Kennard 1986: 161; Guilmartin 1983: 563). Figure 7 illustrates the striking

Gun Size	Bronze Guns				Iron Guns			
	Length	Weight			Length	Weight		
<i>shot weight</i>	<i>feet</i>	<i>cwt</i>	<i>lbs</i>	<i>kg</i>	<i>feet</i>	<i>cwt</i>	<i>lbs</i>	<i>kg</i>
42-pdr	10	66	7392	3356	—	75	8400	3814
32-pdr	9 ½	54	6048	2746	9 ½	57	6384	2898
24-pdr	10	46	5152	2339	9 ½	49	5488	2492
18-pdr	9 ½	40	4480	2034	9 ½	42	4704	2136
12-pdr	9 ½	31	3472	1576	9 ½	36	4032	1831
9-pdr	9	28	3136	1424	9	30	3360	1525
6-pdr	9	19	2128	966	8 ½	21	2352	1068

Table 1. Comparison of the weight of bronze and iron British naval guns, ca. 1742. Adapted from Gardiner 1979: Table 8. Original source, undated table in British Admiralty records (ADM 106/3067). “cwt”=hundredweight, or 112 pounds.

difference between two failed guns, one of bronze and the other of iron. Improved iron casting techniques and gun design, however, would help solve this problem, though the reinforced guns had thicker metal at the breech and reinforces, increasing their weight. While iron guns were never considered as safe as bronze pieces, by the 1630s both England and Sweden were exporting iron guns of reputable quality (Cipolla 1965: 43; Kennard 1986: 161).

The sole disadvantage of bronze as a gunfounding material was its propensity to heat up quickly, which meant that when firing a great number of shots in continuous action it was prone to becoming soft and susceptible to sagging or other bore damage (McConnell 1988: 15). Due to the nature of 16th and early 17th century naval tactics, however, this defect was not readily apparent; by the time of the great broadside to broadside slugfests of the 18th century, ships had already exchanged their bronze guns for iron ones. It would not be until the sieges of the Peninsular campaigns of the early 19th century that this defect became widely known (Kennard 1986: 162; Fisher 1976: 279-280).

The Decline of Bronze Ordnance

Despite the many advantages of bronze cannon, the navies of England, France, the Netherlands, and other principal maritime powers increasingly armed themselves with iron guns starting in the mid-17th century, and the trend was even more pronounced in merchant fleets. The rapidly decreasing cost of iron guns, along with improvements in iron manufacturing technology, made the change inevitable, and most navies had all but abandoned bronze cannon by the 1770s¹ (Kennard 1986: 161; Lavery 1987: 87; Boudriot

¹ The 1775 report of a French spy indicates that Britain made the switch to iron before her traditional enemy: “I have always heard that cannons of iron are dangerous. The British Navy does not object to them: they are lighter than ours and they do not explode. These are recognised facts and cast bronze cannon are no longer used on the lower deck of the largest ships” (Gardiner 1979: 341).



Figure 7. Two guns, one bronze and one iron, that have catastrophically failed (burst). The upper gun is a bronze 6-pdr, cast by Richard Gilpin in 1756 (526 lbs/238.8 kg, 4' 6"/1.372 m long). This English gun burst at St. Lucia in 1783, tearing open longitudinally at the first and second reinforces. Currently housed at the Museum of Artillery Rotunda, Woolwich, from McConnell 1988: Figure 15. The lower gun is all that is left of an iron cannon that exploded, with massive loss of life, while firing on English troops invading St. Augustine on 10 November 1702. Photograph by the author.

and Berti 1993: 312). The great naval encounters of the Revolutionary and Napoleonic wars, therefore, were fought exclusively with iron guns.

In the army, where lighter and more mobile pieces were desirable, bronze ordnance remained in service for some time after their decline as naval weapons. Larger caliber bronze pieces, primarily used for siege guns, were the first to be replaced, as mobility was less crucial for these weapons. Also, as mentioned above, the barrels of bronze guns had a tendency of softening and drooping when overheated by long periods of rapid fire (Kennard 1986: 162). This was especially problematic for siege guns, which were expected to deliver continuous fire for extended periods of time. As early as 1780 artillery treatises reported that iron guns were more effective in this capacity “because the brass did never stand great firing” (Fisher 1976: 280).

While the British army in 1816 officially declared heavy caliber bronze pieces obsolete, lighter caliber field artillery continued to be manufactured and utilized. Bronze cannon used thereafter consisted mainly of 12-pdrs, 9-pdrs, 6-pdrs, and 3-pdrs. Some of these—especially the 6-pdrs—were still being cast in English foundries as late as the Crimean War of 1854-1856 (Kennard 1986: 162). Bronze field (as opposed to siege) and naval howitzers (Figure 8) of various sizes also continued to be used by British troops through the Crimean war; they were longer and more gun-like than their Napoleonic-era predecessors (McConnell 1988: 137-155). In addition, a variety of types and sizes of bronze mortars were used by the British land and sea services (the latter constituting the final remnant of bronze ordnance in the Royal Navy) through the 1860s (McConnell 1988: 113-124).

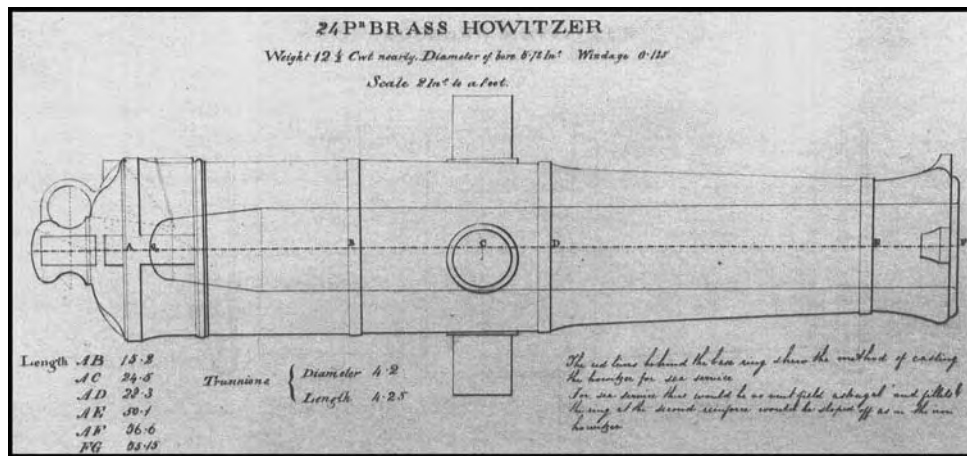

Figure 8. Brass 24-pdr Sea Service Howitzer, ca. 1850, Royal Artillery Institution, Woolwich, U.K. Weight: 12.5 cwt (1400 lbs/635.6 kg), Length: 56.6” (1.44 m). McConnell 1988: 155.

In America, where bronze gunfounding had not become widespread until the 19th century, bronze field artillery were used extensively during the Civil War, the last major conflict to utilize either smooth-bore or bronze ordnance to such a degree. Common bronze field pieces included 6- and 12-pdr guns, the 12-pdr Napoleon gun-howitzer, the

12-pdr mountain howitzer, 12-, 24-, and 32-pdr field howitzers, and the Coehorn mortar (Manucy 1949: 18-19). While the muzzle-loading, smoothbore 12-pdr Napoleon would remain a standard in the U.S. army until the 1880s (Manucy 1949: 13), the cast iron rifled cannons of the U.S. Civil War forced a new era that was the exclusive domain of iron, and eventually steel, gunfounding.

Morphology

Nomenclature

Historic ordnance, despite an inherent simplicity of design, display a surprisingly complex array of parts with a particular nomenclature that must be understood in order to discuss or record them in a meaningful way. Figures 9 and 10 display the named parts of a typical late 18th century bronze cannon, howitzer, and mortar. These schematics have been produced by Rudi Roth, Membership Secretary of the Ordnance Society, who has developed a particular methodology of gun measurement, recording, and illustration (Roth 1989; 1995). The nomenclature labeled in Figures 9-10, and discussed below, is also more or less consistent with that used for bronze guns from previous and later centuries, as well as those made of iron.

The smooth-bore muzzle loading gun, whether constructed of bronze or iron, is essentially a tube of cast metal, closed at one end (the *breech*), with a small hole (*vent* or *touchhole*) at the closed end used to ignite the gunpowder, and, towards the middle of the tube, a squat peg-like projection (*trunnion*) on each side to position it and allow it to pivot in its carriage. The tubular length of the gun is called the *barrel*, while the hollowed out center of the tube is known as the *bore*; the latter is in most cases straight with parallel sides (unlike the barrel, which narrows along its length). The end of the bore nearest the breech (closed end) of the gun, where the gunpowder and shot (called by laymen “cannonball”) were placed for firing is known as the *chamber*. The vent, visible as a hole on the top exterior surface of the breech end of the gun, is a narrow shaft leading to the chamber (allowing the ignition of powder).

The breech end has the thickest walls of any portion of the gun, as it had to withstand the full force of the explosion in the chamber every time the weapon was fired. The widest part of the breech, just behind the chamber, was called the *base ring*. The length of the gun was traditionally measured from this point forward. Forward of the base ring, the main part of the gun was divided up into three sections: the *first reinforce*, the *second reinforce*, and the *chase*. The gun tapered gradually through these sections, most noticeably at their junctions. These junctions were marked by flat, relatively wide rings (*first reinforce ring*, *second reinforce ring*) and sometimes by adjacent *ogees*, which were also molded rings but with a double-curve or S-shaped cross-section. Another type of molded ring is the *astragal*, which is semi-circular in cross-section; *fillets* are yet another molded band, very narrow and flat in cross-section, and always positioned on either side of an astragal. Astragals were usually placed a little forward of the second reinforce ring,

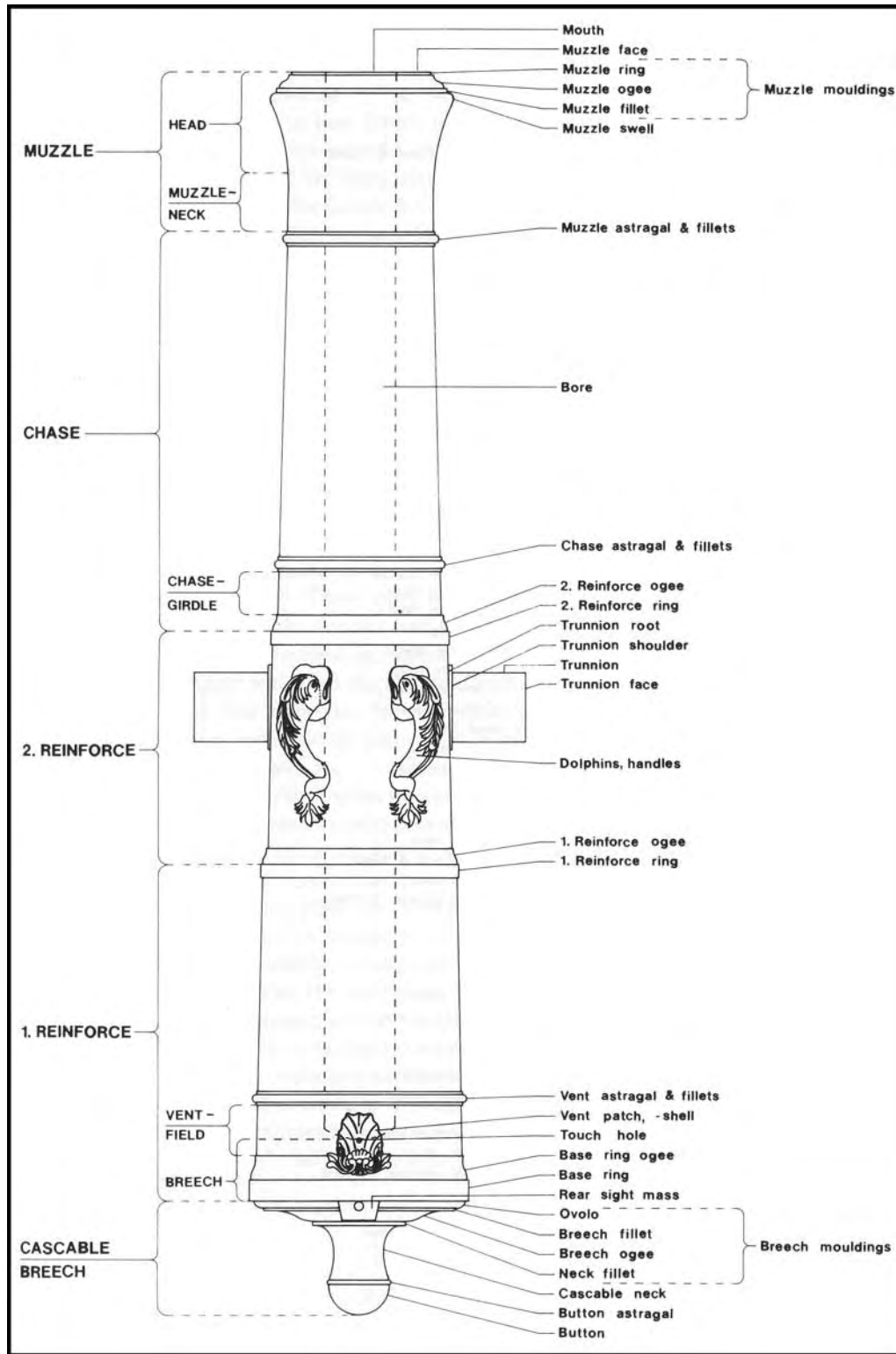

Figure 9. Labeled parts of a late 18th century bronze gun. Drawn by Rudi Roth (1995: 127).

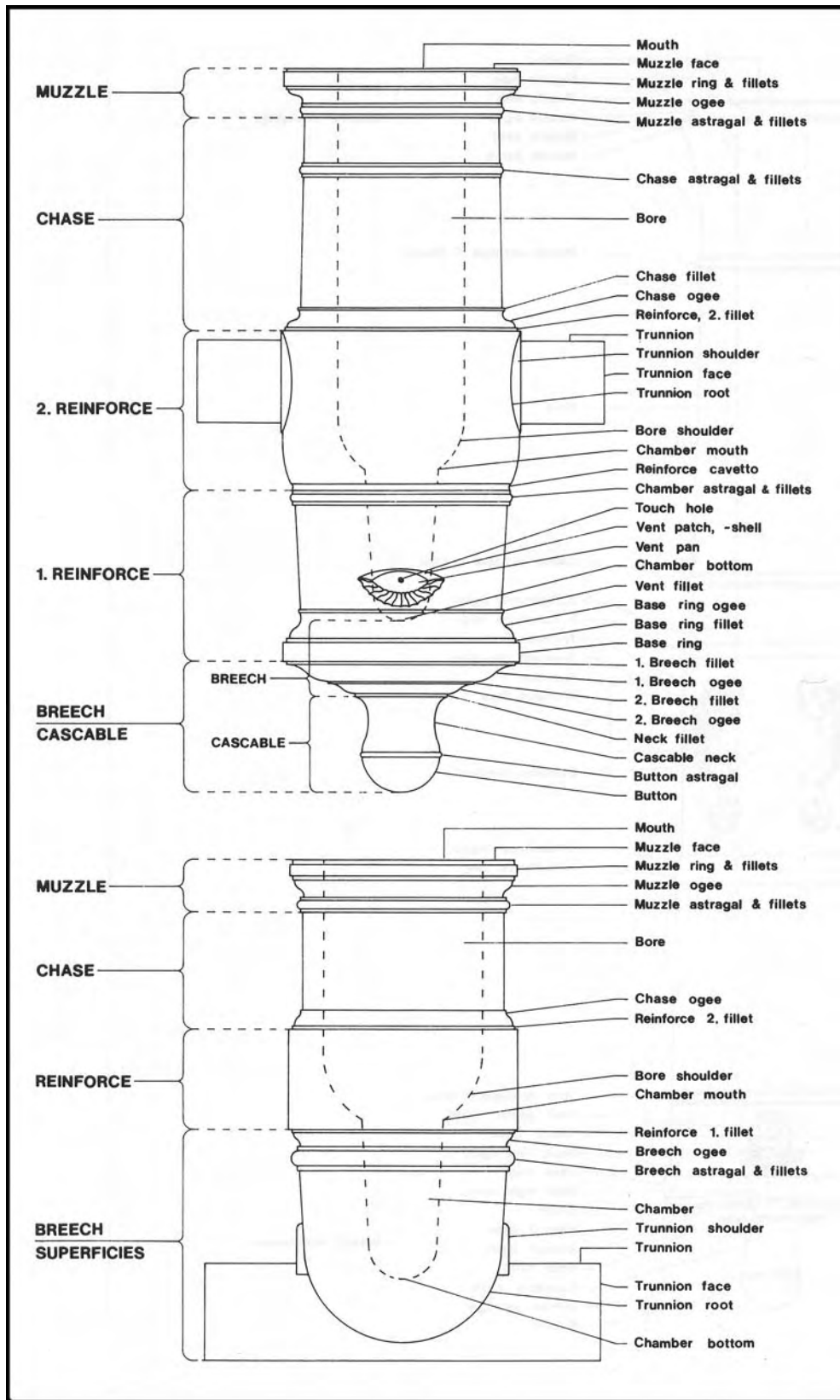

Figure 10. Labeled parts of a late 18th century bronze howitzer (top) and mortar (bottom). Drawn by Rudi Roth (1995: 128)

and at the forward boundary of the chase. At the opposite (breech) end of the gun, an astragal (with its accompanying fillets) was usually present just forward of the vent (marking the boundary of the *vent field*).

The forwardmost section of the gun, the open end in front of the chase, was known as the *muzzle*. The barrel is at its narrowest here (at the *muzzle-neck*), but it flares to a wider diameter (the *head* or *swell of the muzzle*), and then narrows sharply again. This point is also marked with molded rings (collectively termed *muzzle moldings*, they could be fillets, ogees, or astragals). Some early guns of the 16th and 17th centuries did not have swell of the muzzle, ending instead in a series of heavy and increasingly wider molded rings; this can be seen in Figure 3 (Manucy 1945: 41). The flat surface on the extreme front of the gun, pierced by the hole (*mouth*) from which the shot was fired, is termed the *muzzle face*.

The *cascable* originally referred to the round knob at the breech end of the gun, though eventually this term came to represent the entire area behind the base ring (at which time the projecting knob was known as the *button*) (Lavery 1987: 88). The buttons on early guns (16th and 17th centuries) tended to be smaller, and sometimes irregularly shaped (see Figures 1-2), than those in the 18th century, when the neck of the cascable was equal in diameter to the bore, and the button slightly wider and spherical (Lavery 1987: 97). Later guns, especially British ones, had a large, thick ring attached to (and eventually replacing) the button. Examples of this can be seen in Figures 5 and 6. Mortars did not have cascables or buttons, but simply a rounded base called the *superficies* (Figure 1 depicts a very rare exception, even for the 16th century).

As mentioned above, the trunnions project from either side of the barrel, at a point just forward of the gun's center of gravity. This way the gun, when in its carriage, could pivot up and down on its trunnions, and rest on its breech. The exception to this was the mortar, whose trunnions were always cast at the bottom (again, the mortar pictured in Figure one is anomalous if not unique with its trunnions located towards its center of gravity). Seventeenth-century cannon trunnions tended to taper as they extended from the barrel, but by 1716 they were cylindrical in shape, and equal in length and diameter to the bore (Lavery 1987: 97).

Dolphins, or lifting handles, were almost exclusively fitted on bronze (as opposed to iron) guns. Their name originates in the frequent decorative practice of depicting them as leaping dolphins (Figure 19). There was almost always a single pair of dolphins, on the upper surface of the gun usually just above its trunnions. Some early guns might have a single vertical dolphin in place of the cascable button². Another, less common feature on

² Examples include the Armada gun cast in 1556 pictured in Figure 3, the guns from the 1618 Spanish shipwreck *San Martin* off the east coast of Florida, the gun recovered in 1980 from the 1622 Spanish shipwreck *Santa Margarita* in the Florida Keys, the guns from the *Vasa* lost in 1628 (their dolphins appear to be in the shape of land animals; see Figure xx), and a number of Portuguese 11- and 26-pdrs cast between 1640 and 1656 recovered from the 1668 galleon *Santíssimo Sacramento* off Brazil (Guilmartin 1983: Figures 4, 6).



Figure 11. Portuguese *canon-perrier* recovered from the Spanish galleon *San Diego*, lost in Manila Bay in December 1600. Note this form of *perrier* is longer than usual (see Figure 1). This is a somewhat rare example of a gun equipped with lifting rings rather than dolphins. The emblems on the chase are enlarged, and represent the Royal Foundry as well as King Manuel (1495-1521). The gun weighs 741 kg (1608 Portuguese *livres*), measures 2.57 m (about 7 Portuguese *pie*ds), has a caliber of 17.3 cm, and fired a shot weighing 5.5 kg (12 *livres*). From Carré et al 1994: 208.

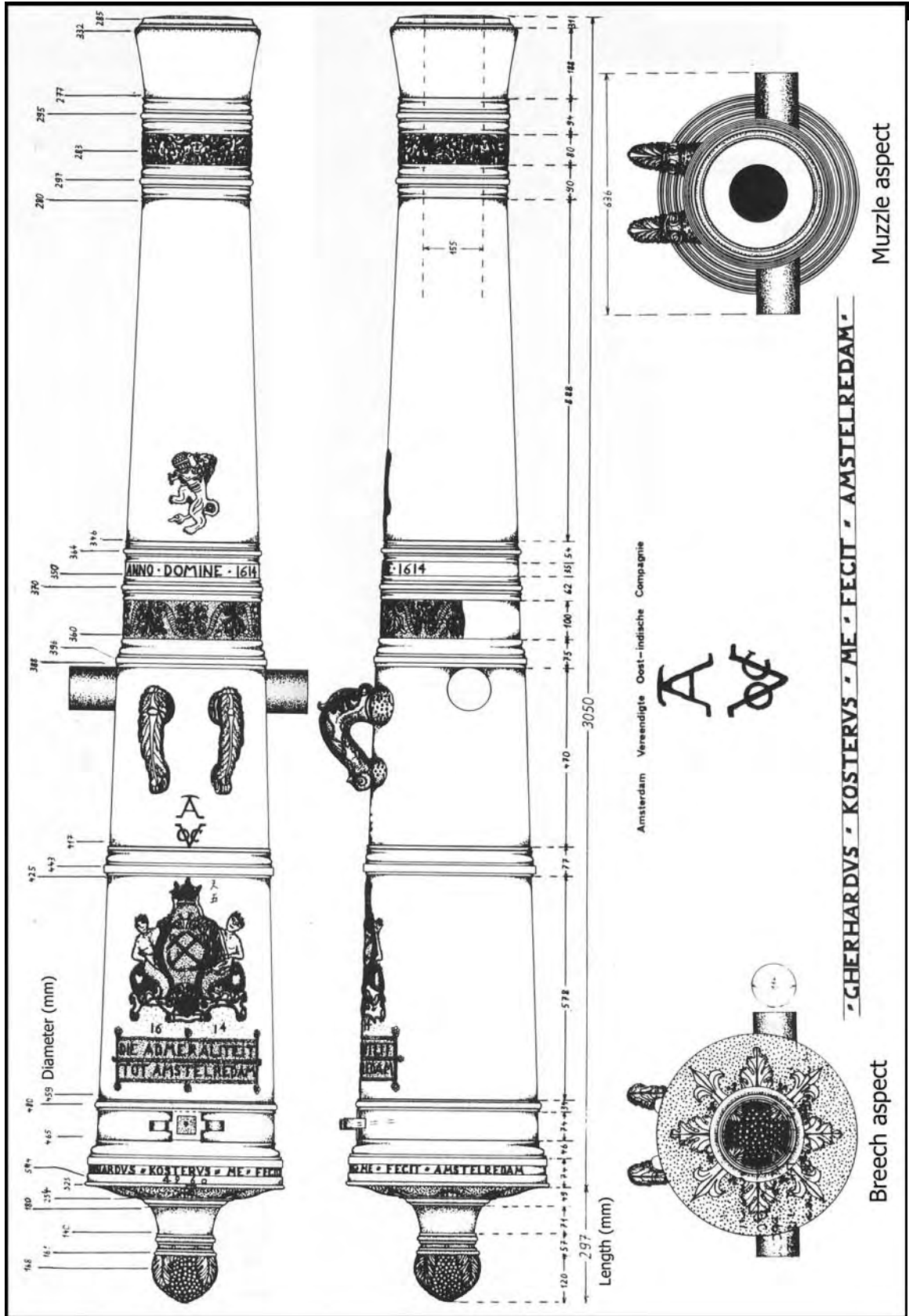

Figure 12. Dutch East India Company gun, cast in 1614. Drawn by Rudi Roth, from Carpenter Plate 201.

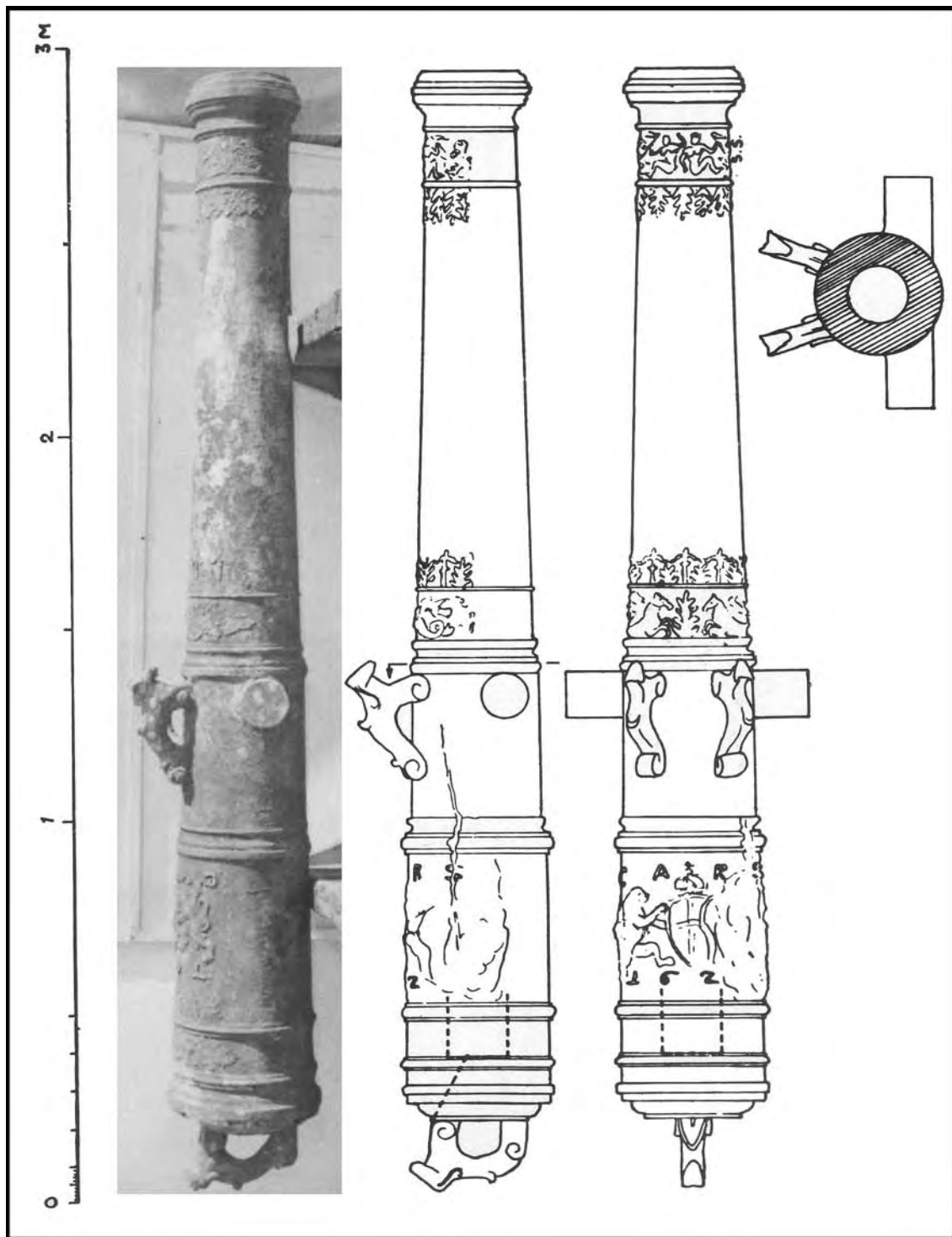

Figure 13. Photograph and drawing of one of the 48 bronze 24-pdr guns on board the *Vasa* when it foundered in Stockholm Harbor in 1628. Weight: 2800 lbs (1135 kg). The Swedish coat of arms is obscured but the letters G.A.R.S.—“Gustavus Adolphus Rex Sueciae” (“Gustav Adolph King of Sweden”)—can be easily discerned. Drawing by Sam Svensson, from Padfield 1973.

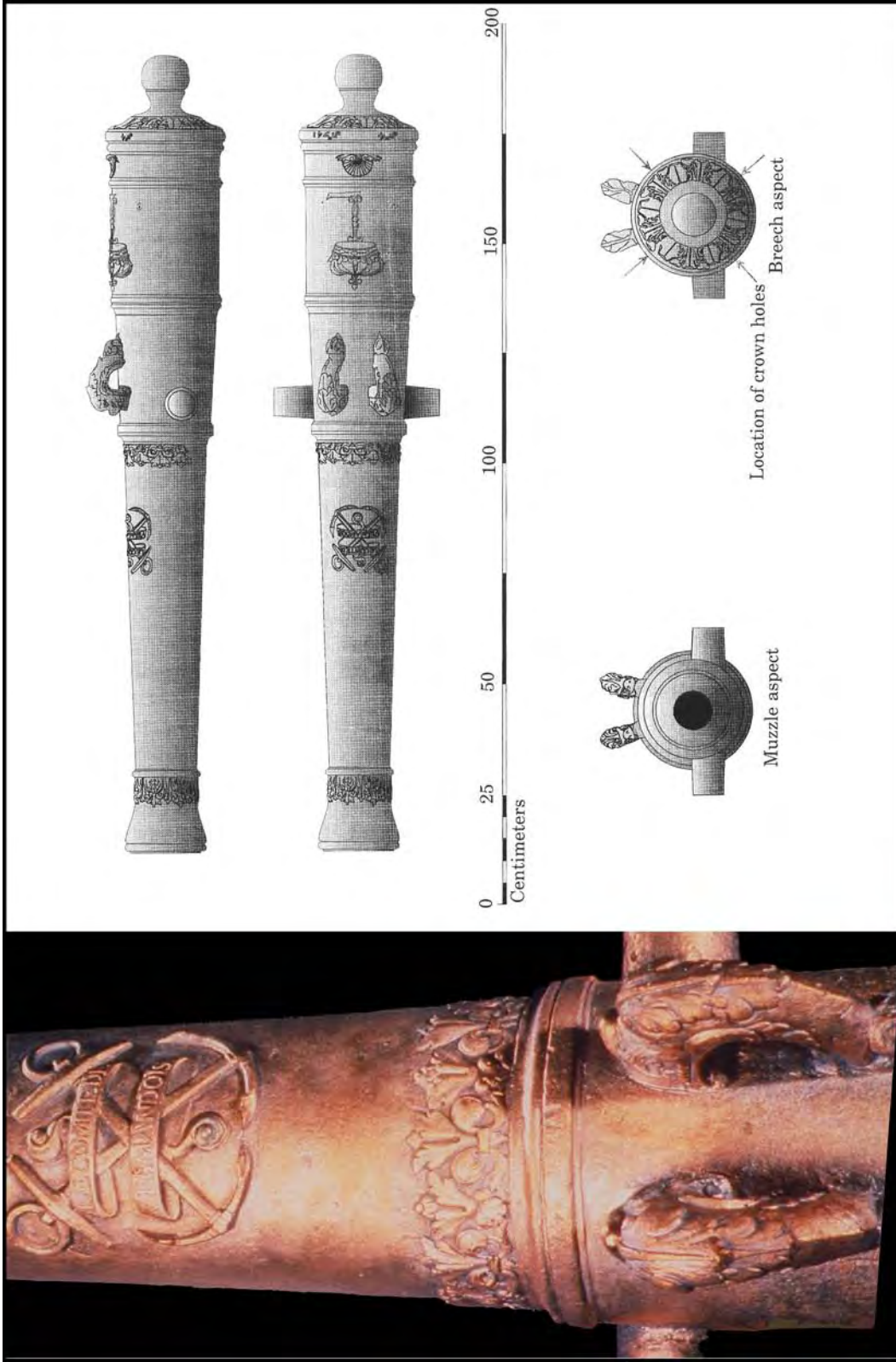

Figure 14. Bronze 4-pdr gun discovered by the author on the 1686 wreck of *La Belle*. It was cast at the Rochefort foundry, France, by master founder Jean La Tâche sometime between 1670 and 1679. The crossed anchor device is the cipher of the Count of Vermandois, Louis de Bourbon, the *Grand Admiral* of France. The crown and “L” is the crest of King Louis XIV (see also Figures 20-21). Length: 183 cm, weight: 741 French pounds (*livres*) or 360.2 kg. Drawing by D.H. Keith, courtesy of Ships of Discovery and the Texas Historical Commission.

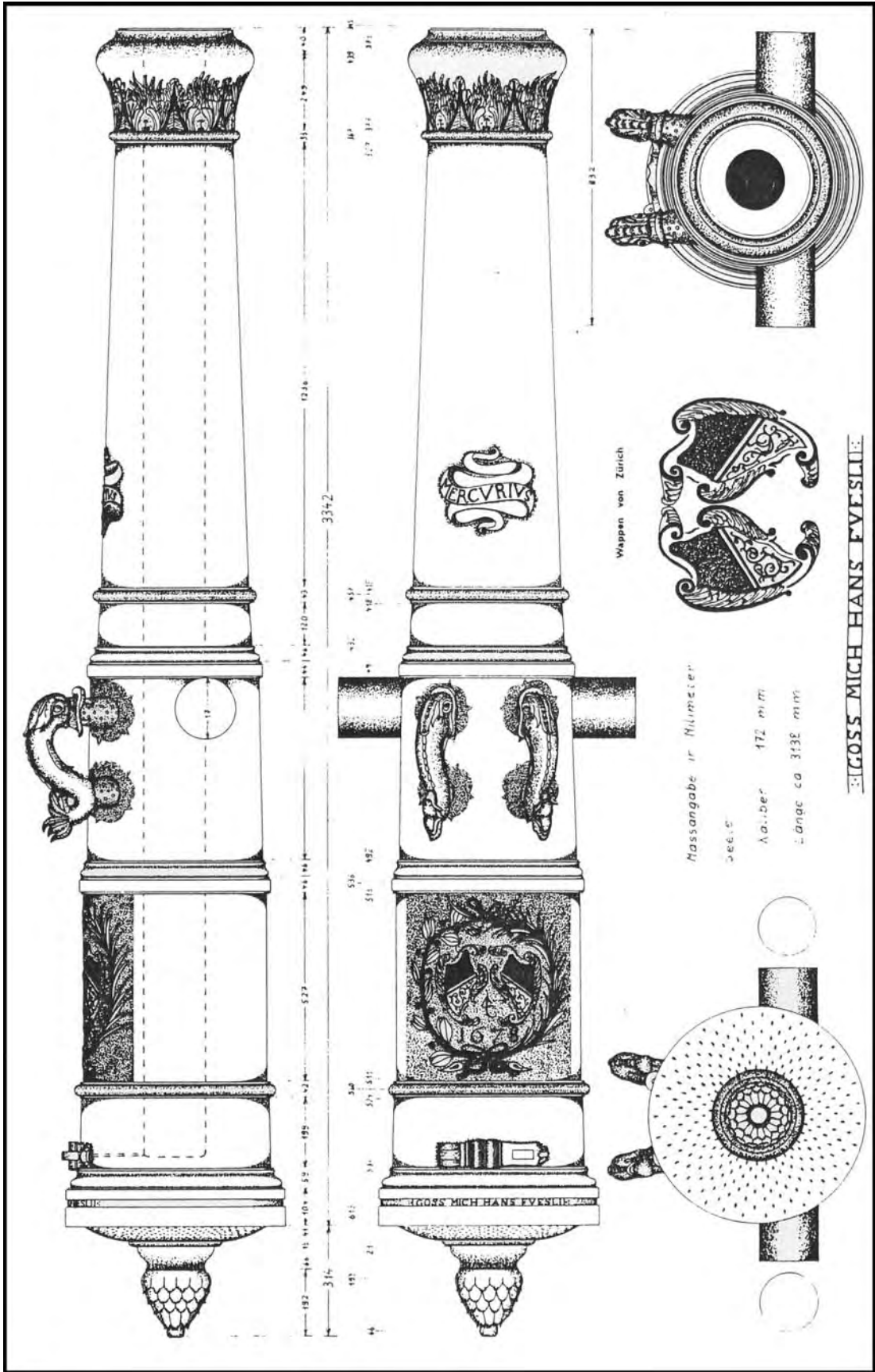

Figure 15. Elaborately decorated Swiss 24-pdr, named "Mercurius." Cast in 1678 by Johann Füssli, one of a famous family of gun- and bell-founders active in Zurich from the mid-15th to the early 19th centuries. This gun is on display at the Landesmuseum in Zurich. Drawn by Rudi Roth (1989; Figure 3).

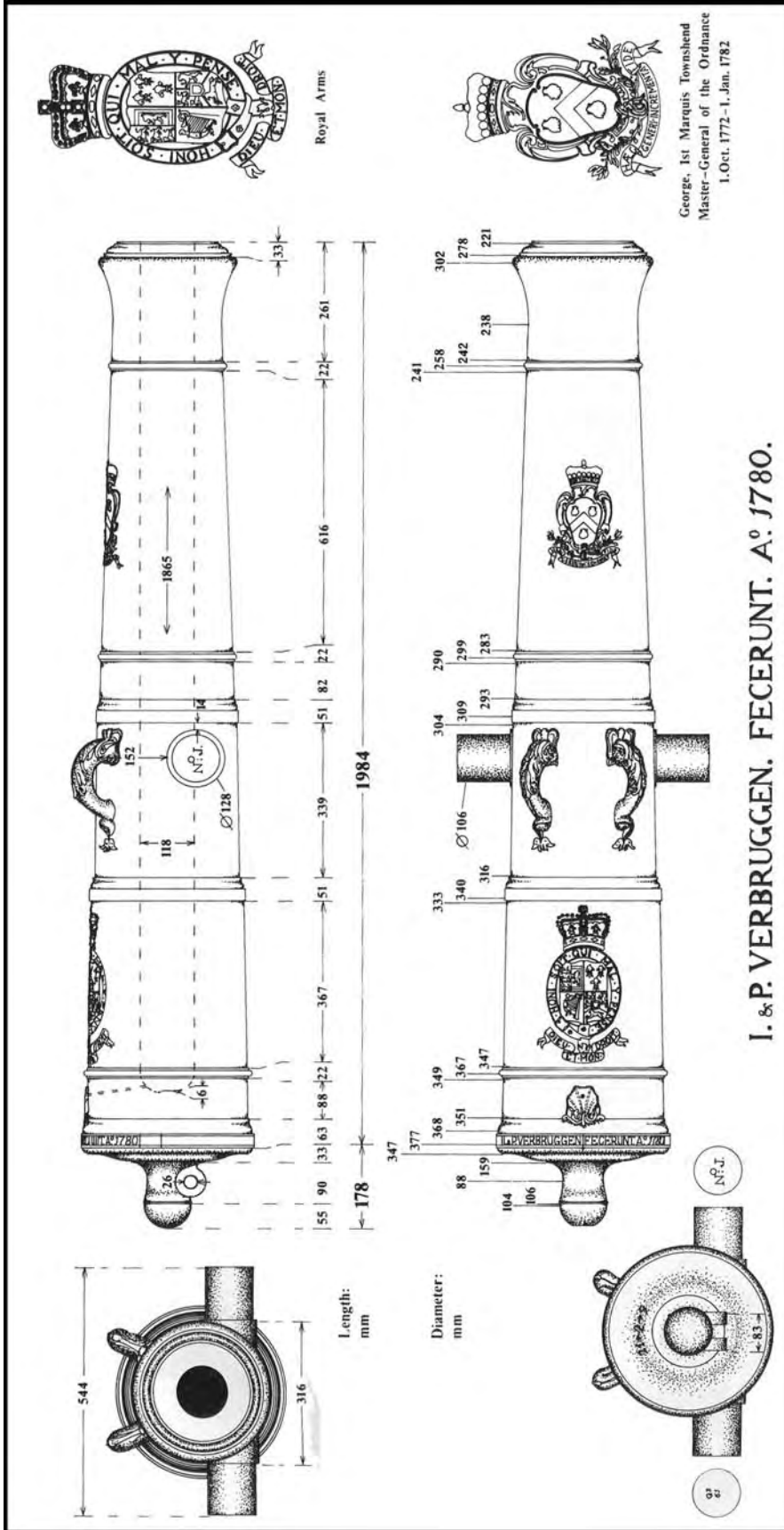

Figure 16. An "old" medium 12-pdr cast by the Verbruggen family at the Royal Brass Foundry, Woolwich, England, in 1780. This model weighed 21 hundredweight (2352 lbs or 1067.8 kg) and measured 6'6" or 1.98 m. It continued to be made until 1795, when it was superseded by the "new" version that was the same length but weighed only 18 cwt. This particular gun, housed in the Blackdown Barracks at Deepcut, has a fault at the bottom of the bore likely caused by too deep final boring after proof. Drawing by Rudi Roth, from de Beer 1991: 226.

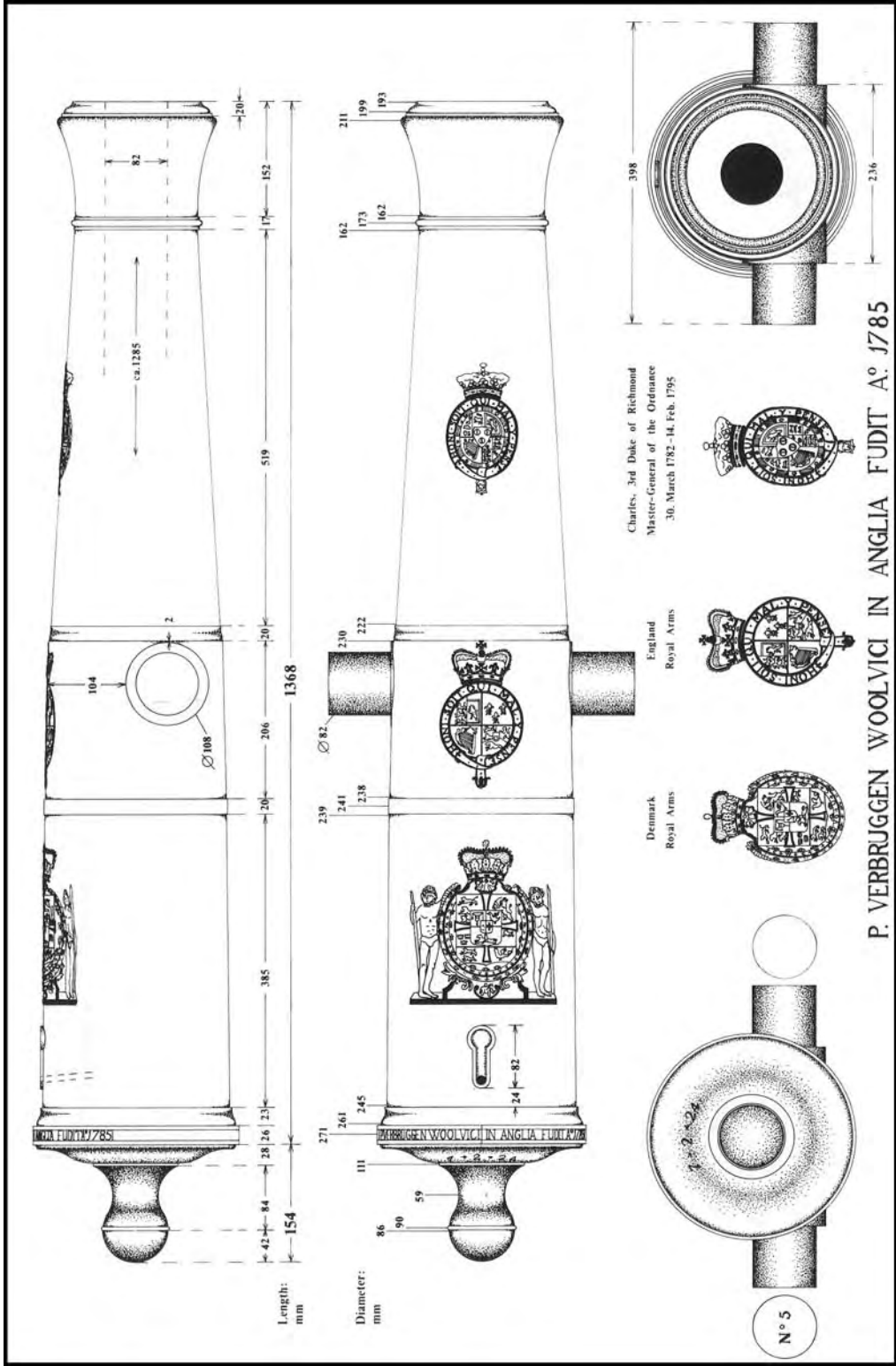

Figure 17. A British 4-pdr, non-standard pattern, cast by the Verbruggens at Woolwich in 1785, and now housed in the Tower of London. Only ten of these were ever cast, for the armament of a 200-ton pleasure yacht presented to the future King Frederick of Denmark. Thus it is somewhat unique in that it bears the royal arms of both England and Denmark (the former is in place of the usual pair of dolphins). The gift was sent back after the Danish wars. Length: 4' 6" (1.37 m), weight: 7 1/2 cwt (840 lbs or 381.4 kg). Drawn by Rudi Roth, from de Beer 1991: 224.



Figure 18. Spanish fortification gun and detail of crest. The monogram is that of King Carlos IV of Spain, who reigned from 1788-1808. This gun, typical of later bronze ordnance, is sparsely decorated—note the plain dolphins and engraved rather than relief molded coat of arms (compare with Figure 20). The smooth surface enabled by engraving as opposed to casting relief allows for machine finishing, making the gun significantly cheaper and faster to manufacture. This cannon is housed at the *Castillo de San Marcos* National Monument in St. Augustine. Photograph by the author.

some early guns were large lifting rings (often in sets of four, sometimes with another at the cascable); a Portuguese example is illustrated in Figure 11.

Figures 11-18 are included to provide a cross-cultural comparison of a variety of bronze guns, which come from a range of archaeological and fortification contexts dating from the 16th to late 18th/early 19th centuries. Most of the features introduced in this section, along with various artistic decorations discussed below, are present on these guns.

Decoration

Bronze guns, in accordance with their greater expense, status, and prestige, were invariably much more heavily decorated than their iron counterparts. While the latter might have, if anything, a royal badge on the second reinforce or base ring, bronze guns usually featured decorated dolphins (Figure 19) in addition to two coats of arms on the first reinforce and chase respectively (Lavery 1987:88). The first reinforce usually displayed the monogram or coat of arms of the ruler for whom the gun was cast (as in Figures 3,5,13-18, and 20), while the armorial device on the chase was often the cipher or coat of arms of the officer in charge of ordnance matters (Figures 5, 14, and 16-18); for example, the Master General of the Ordnance in England or the *Grand Admiral* or *Grand Maitre de l'Artillerie* in France (Kennard 1986: 21).

In addition to heraldic devices, bronze guns—especially those cast in the 16th, 17th, and early 18th centuries—often featured floral or abstract designs in relief around the reinforce rings, astragals, or fillets (see Figure 14, left). The vent was usually decorated as well, often with a scallop shell (Figure 20, middle) or similar design, and the cascable and button could display floral (as in Figure 21) or other patterns, or be designed in the shape of an animal or anthropomorphic face (an example of the latter can be seen on the mortar in Figure 4). While usually simply aesthetic in nature, these decorations could sometimes serve a practical purpose, such as the French guns mandated by the *Système Vallière* in 1732. Designed by the Inspector of Artillery Jean Florent de Vallière, all royal ordnance featured a different breech design—the cascables formed as the heads of birds, animals, or classical masks—for each of the five official calibers for easy identification (Thatcher 1985: 2).

Even more practical (both in antiquity and for the modern archaeologist) are engraved, relief, or incuse markings conveying diagnostic information. Quantitative and provenience-related data such as the date and place of founding, weight of the gun, gunfounder's name or cipher, and inventory number were often located around the base ring. Similar marks were frequently positioned on the faces of the trunnions. Other inscriptions were more symbolic in meaning; for example, some individual guns had peculiar nicknames (Figure 15) or significant phrases which were prominently displayed,

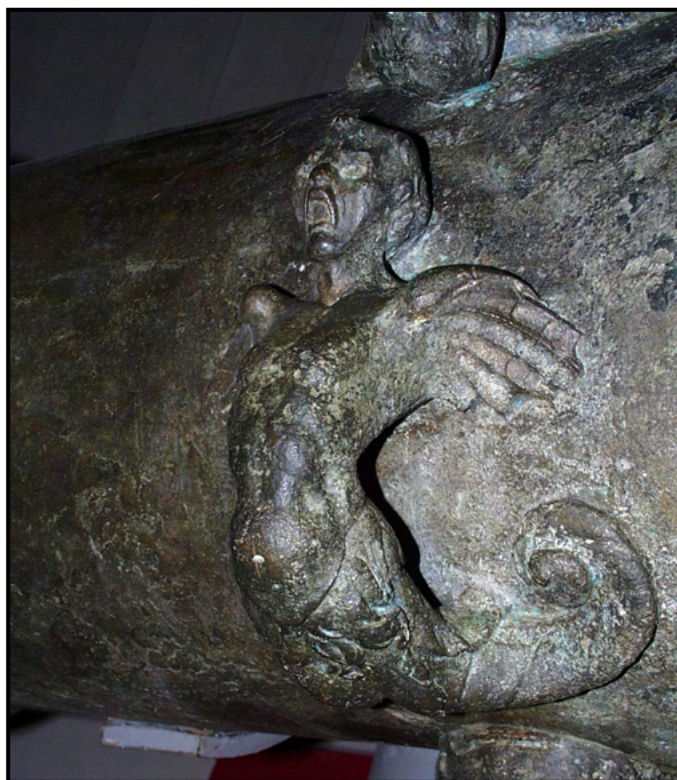
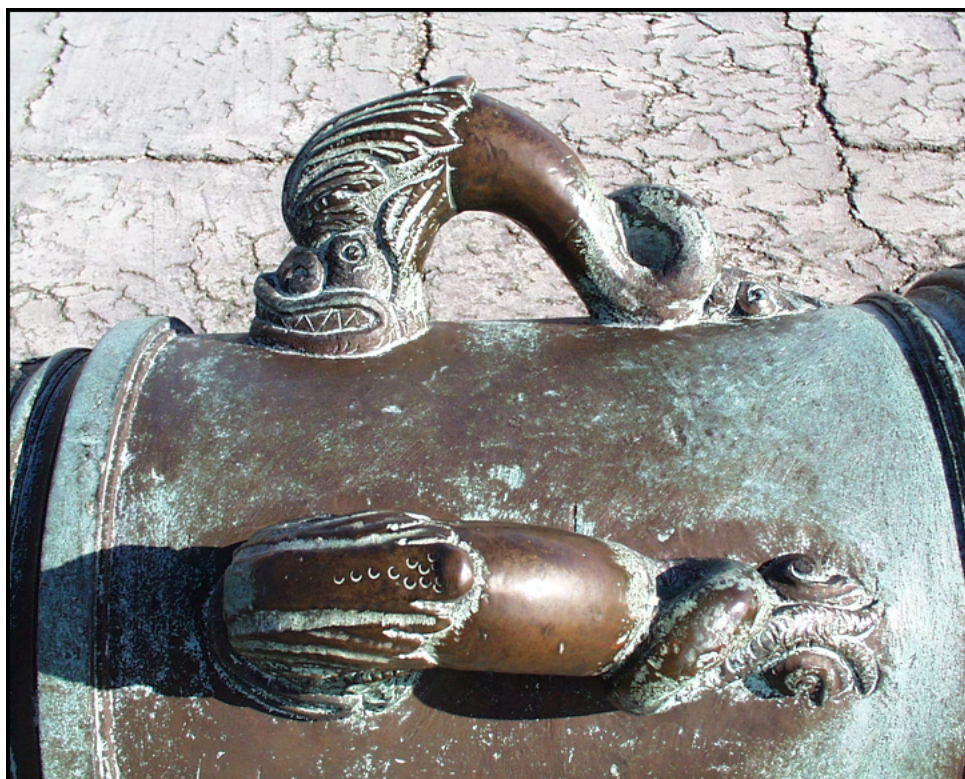

Figure 19. Top: Traditional leaping dolphin design for lifting handles. From a Spanish gun cast in 1764. Bottom: Less common, though also known as dolphins, were zoo- or anthropomorphic motifs such as this screaming siren or mermaid from a gun recovered from King Henry VIII's ship *Mary Rose*, lost in 1545. Both photographs by the author.



Figure 20. Crests of three great kings. Left, the Tudor Rose of King Henry VIII, on a cannon (the same pictured in Figure 19, bottom) from *Mary Rose* (1545). In the middle, the crown and “L” of the Sun King, Louis XIV, from the *Belle* cannon (1686; see Figure 14, 21). Note the scallop shell motif at the touchhole, below the L. At right, the coat of arms of Spain’s King Carlos III, from a cannon cast in 1764 (the same gun pictured in Figure 19, top). All these royal crests are located on the first reinforce of their respective guns. All photographs by the author.



Figure 21. The fully-conserved *Belle* 4-pdr as seen from behind, mounted on a replica naval carriage as part of a traveling exhibit designed by the Texas Historical Commission and Ships of Discovery. While the button is plain, the rest of the cascable is decorated with repetitions of an acanthus leaf and blossom design (compare with the similar design, involving fleur-de-lys, above the reinforce ogee in Figure 14 on the left). The acanthus leaf motif was a common one, imitating Corinthian column decoration. This gun was cast sometime during the 1670s in the Rochefort foundry, France. Photograph by Kay Chernush, from Roberts 1997: 53.

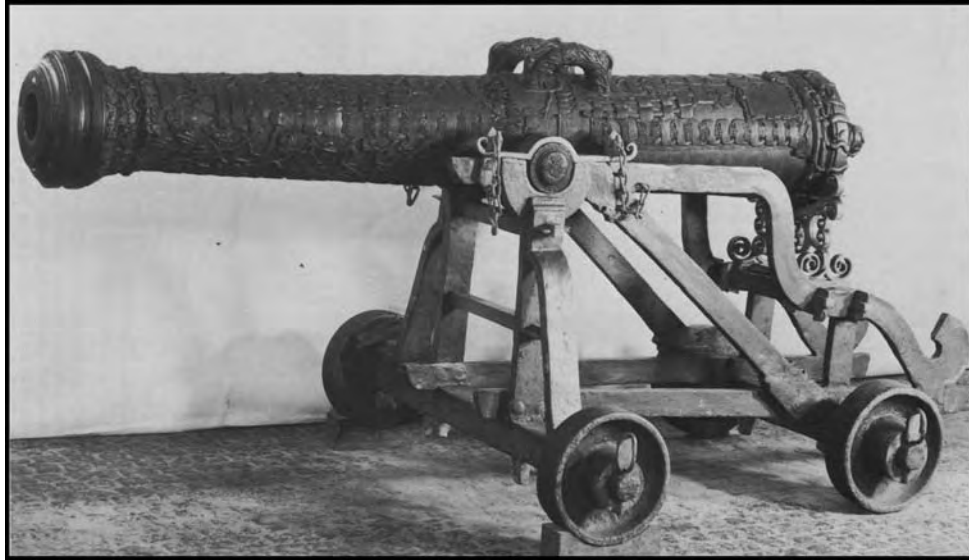

Figure 22. One of a pair of elaborately decorated 27-pdrs cast for the Count of Oldenburg in 1633 by Copenhagen's master founder Felix Fuch. Kennard 1986: 17.

often on forward extent of the chase³.

In general, fortress guns bore more ornamentation than naval or field weapons⁴ (Lavery 1987: 88), and occasionally ceremonial weapons were produced for a monarch bearing an almost absurd amount of decoration. An extreme example is the two famed Oldenburg demi-cannon made for a relative of Danish King Christian IV by the royal gunfounder, Felix Fuch, in 1633. These 27-pdr guns, over 10 feet in length, were ornamented with an elaborate design incorporating 512 individual cartouches (each bearing an incised name and coat of arms in low relief) in three family trees—showing a direct descent from Charlemagne—all intertwined by a higher relief series of tree branches adorning the muzzle, dolphins, cascable, and underside (Figure 22). Now housed in the Tøjhus Museum in Copenhagen, the two sets of decorations took Fuch three years to complete (Kennard 1986: 22).

The Oldenburg guns notwithstanding, bronze guns were primarily designed to be killing machines and they did tend to become more plain as time passed. The English were the first to simplify the design and decoration of their ordnance in an ongoing consideration of efficiency and economy. Other nationalities, especially the French, Spanish, and Italians, continued to cast elaborately decorated guns through the late 18th century (some Italian founders even engraved their shot, an aesthetic which without doubt impaired performance) (Tucker 1989: 15). As early as 1674, however, an Ordinance for French

³ These usually endorse the power of the monarch for whom the gun was cast. For example, several of the 18th century Spanish guns at the *Castillo de San Marcos* National Monument in St. Augustine, Florida are labeled “*Violati Fvlmina Regis*,” or “Fire from an Angry King,” and a Prussian gun recovered from Plymouth Sound read “*Ultima Ratio Regis*,” or “Final Argument of Kings” (Carpenter 1993: 50).

⁴ This is readily apparent to visitors at the *Castillo de San Marcos*, which is garrisoned with a number of highly decorated bronze pieces dating mainly to the 18th century.

Naval Forces mandated certain limits to decoration in order to streamline the production process:

The decorations of the pieces will be in accordance with the models which will be sent by His Majesty, and it will be noted that they will be made very uniform, because of the quantity required for the Navy, which does not allow the necessary time to mold and repair the ornaments (Keith et al 1997: 151)

The bronze cannon recovered from the shipwreck *La Belle*, cast at the Rochefort foundry sometime between 1670 and 1679, displays some asymmetric artwork at the muzzle and breech (Figure 21, though the misalignment is hard to make out), possibly constituting evidence such authorized expedience (Keith et al 1997: 150-151).

The advent of the Revolutionary and Napoleonic wars in the late 18th century necessitated a dramatic increase in the production of ordnance, which led to even greater design simplifications. This included the abandonment of ornament in relief in favor of engraved decorations (as in Figure 18), which allowed a much faster production process since the smooth surface of the barrel could be machine-finished with a turning lathe (Kennard 1986: 21). At about the same time the dolphins more often than not were cast as simple loops without superfluous artwork (again, see Figure 18) (Kennard 1986: 11). After the Napoleonic Wars, and through the end of the period of muzzle-loading bronze ordnance in the mid-19th century, most decoration other than ancillary markings was eliminated (as in Figure 8).

Composition

Copper by itself is of course too soft for use in artillery, but the addition of the right proportion of tin produces a tenacious alloy harder than either constituent, and with a melting point somewhat lower than that of copper but considerably higher than that of tin. The great advantage of bronze ordnance was its strength; its disadvantage (besides expense) was its aforementioned tendency to heat up quickly, meaning that it could not sustain rapid firing over a long period of time.

While this study uses the technically correct term “bronze” for the copper/tin alloy used by historic gunfounders, the word “brass” was that in general use until the 1840s, when—ironically—the ordnance in question was nearing obsolescence (Kennard 1986: 23). French terminology could be even more confusing, as contemporary manuscripts used *cuiivre* interchangeably for both pure copper and for bronze (de Beer 1991: 204). A related term was “gun-metal,” which meant a specific alloy of (usually) 91% copper and 9% tin (while “bell-metal” specified 70-78% copper and 22-30 % tin). The former proportion was traditionally preferred for “brass” cannons and howitzers, though McConnell (1988: 15) notes that a slightly different mix of 88% copper and 12% tin was used for mortars.

Gunfounders sometimes added other metals, usually brass (true brass, an alloy of copper and zinc) or latten (a brassy alloy with copper, zinc, and an often heavy proportion of lead). A somewhat skeptical 18th century writer noted that the addition of brass in small quantities was thought by some to “promote the union of the Tin with the Copper” (McConnell 1988: 15) while others believed that the admixture of latten would give the final product a better color (Kennard 1986: 14).

Modern metallurgical analysis of historic ordnance has confirmed these kinds of additions. Analysis from a number of British bronze pieces dating between ca. 1700 and 1870 in the collection at the Tower of London showed that both zinc and lead were present in small proportions, as well as trace quantities of various other elements (Blackmore 1976: 407-409). As seen in Table 2, below, guns cast towards the end of the period in question tended to be closer to true bronze (copper and tin only):

Type of Gun	Date	% Copper	% Tin	% Zinc	% Lead
2-pdr gun	ca. 1700	79.5	11.3	0.50	3.55
Mortar	1726	89.1	6.8	0.30	0.35
24-pdr gun	1743	90.8	2.25	0.10	0.75
Howitzer	1798	86.0	8.75	0.15	0.80
Howitzer	1810	87.1	6.65	0.15	1.00
6-pdr gun	1850	87.5	8.5	0.05	0.50
9-pdr R.M.L.	1870	88.7	8.1	0.05	0.40

Table 2. Composition of selected ordnance at the Tower of London, ca. 1700-1870. From McConnell 1988: 16. “R.M.L” = rifled muzzle-loading

Conclusion

The original intent of the author was to include a detailed overview of bronze ordnance manufacture as a third section of this report. This, however, has proved beyond the scope of the current study, of which the text alone is already straining against the proscribed page limit! The art of bronze gunfounding, fortunately, has been well documented by a number of contemporary writers in a variety of well-illustrated encyclopedias and treatises. Readers are referred to the following modern sources for an overview of the gunfounding process: de Beer 1991; Kennard 1986: 10-24; McConnell 1988: 15-28; Lavery 1987: 81-84; Ffoulkes 1969: 8-20; Guilmartin 1983: 561-563; and Thatcher 1985: 5. Of these the first, which includes fifty watercolors painted by the Verbruggens themselves depicting every step of the founding and machining process at their late 18th century Woolwich Brass Foundry, is by far the most complete and elucidating.

Nevertheless, the present study does provide a comprehensive introduction to the form and evolution of a weapon that, in its heyday, was universally recognized as the most

advanced in the world. Unlike any other military hardware before or since, bronze cannon—no two of which were ever exactly alike—were imbued with an intangible sense of prestige and power, reflected in beautifully evocative decorations, which made them simultaneously instruments of destruction and true works of art.

References

Blackmore, H.L.

1976 *The Armouries of the Tower of London. Volume I: Ordnance.* London.

Boudriot, Jean

1992 *L'Artillerie de Mer: Marine Française, 1650-1850.* Ancre, Paris.

1986 *The Seventy-Four Gun Ship. Volume 2: Fitting out the Hull.* Jean Boudriot Publications, Ashley Lodge, Rotherfield, United Kingdom.

Boudriot, Jean and Hubert Berti

1993 *The History of the French Frigate 1650-1850.* Jean Boudriot Publications, Ashley Lodge, Rotherfield, United Kingdom.

de Beer, Carel (ed.)

1991 *The Art of Gunfounding: The Casting of Bronze Cannon in the Late 18th Century.* Jean Boudriot Publications, Ashley Lodge, Rotherfield, United Kingdom.

Carpenter, Austin

1992 *Cannon: The Conservation, Reconstruction, and Presentation of Historic Artillery.* Halsgrove Press, Devon, United Kingdom.

Carré, Dominique, Jean-Paul Desroches, and Franck Goddio

1994 *Le San Diego: Un trésor sous la mer.* Réunion des Musées Nationaux, Paris.

Caruana, Adrian B.

1994 *The History of English Sea Ordnance, 1523-1875. Volume I, The Age of Evolution, 1523-1715. Volume II, The Age of the System, 1715-1815. Volume III, The Age of Change, 1815-1875.* Jean Boudriot Publications, Ashley Lodge, Rotherfield, United Kingdom.

Cipolla, Carlo

1965 *Guns, Sails, and Empires: Technological Innovation and the Early Phases of European Expansion 1400-1700.* Pantheon Books, New York.

Fisher, Charles

1976 The Great Guns of the Navy, 1797-1843. *The American Neptune* 36(4): 276-295.

Ffoulkes Charles

1937 *The Gun Founders of England.* Cambridge University Press, Cambridge.

Gardiner, Robert

1979 Fittings for Wooden Warships, Part III: Guns. *Model Shipwright* 20: 338-353.

1993 Guns and Gunnery. In *The Line of Battle: The Sailing Warship, 1650-1840*, edited by Brian Lavery, pp. 146-163. Conway's History of the Ship Series. Conway Maritime Press, London.

Guilmartin, John F. Jr.

1983 The Guns of the *Santissimo Sacramento*. *Technology and Culture* 24(4):559-60

- 1994 Guns and Gunnery. In *Cogs, Caravels, and Galleons: The Sailing Ship 1000-1650*, edited by Richard W. Unger, pp. 139-150. Conway's History of the Ship Series. Conway Maritime Press, London.
- Hogg, Ian V.
1974 *A History of Artillery*. Hamlyn, London.
- Howard, Frank
1979 *Sailing Ships of War 1400-1860*. Mayflower Books, New York.
- Hughes, B.P.
1969 *British Smooth-Bore Artillery: the Muzzle-Loading Artillery of the 18th and 19th Centuries*. Arms and Armour Press, London.
- Jackson, Melvin H. and Charles de Beer
1974 *Eighteenth Century Gunfounding*. Smithsonian Press, Washington, D.C.
- Keith, Donald H., Worth Carlin, and John de Bry
1997 A Bronze Cannon from *La Belle*, 1686: its Construction, Conservation, and Display. *International Journal of Nautical Archaeology* 26(2): 144-158.
- Kennard, A.N.
1986 *Gunfounding and Gunfounders: A Directory of Cannon Founders from Earliest Times to 1850*. Arms and Armour Press, London.
- Lavery, Brian
1987 *The Arming and Fitting of English Ships of War, 1600-1815*. Conway Maritime Press, London.
- Lewis, Michael
1961 *Armada Guns: A Comparative Study of English and Spanish Armaments*. George Allen & Unwin Ltd., London
- Manucy, Albert
1949 *Artillery Through the Ages: A Short Illustrated History of Cannon, Emphasizing types used in America*. Division of Publications, National Park Service, U.S. Department of Interior, Washington, D.C.
- Martin, Colin J.M
1997 Ships as Integrated Artefacts: the Archaeological Potential. In *Artefacts from Wrecks: Dated Assemblages from the Late Middle Ages to the Industrial Revolution.*, edited by Mark Redknapp. Oxbow Monographs. vol. Oxbow Monograph 84. Oxbow Books, Oxford.
- McConnell, David
1988 *British Smooth-Bore Artillery: A Technological Study*. Parks Canada, Ottawa.
- Padfield, Peter
1973 *Guns at Sea*. Hugh Evelyn, Ltd., London.
- Roberts, David

1997 Sieur de La Salle's Fateful Landfall. *Smithsonian* 28(1): 40-53.

Roth, Rudi

1989 The Measuring of Cannons. *Journal of the Ordnance Society* 1: 51-62.

1995 The Reporting of Ordnance: The Guns from the *Mauritius*, a Casebook Study. In *The Archaeology of Ships of War*, edited by Mensun Bound, pp. 120-129. International Maritime Archaeology Series No. 1. Anthony Nelson, Ltd., Oswestry, United Kingdom.

Thatcher, Joseph

1985 *Cast for War: A History of Muzzle-Loading Artillery*. State of New York Bureau of Historic Sites, Waterford.

Tucker, Spencer

1989 *Arming the Fleet: U.S. Navy Ordnance in the Muzzle-Loading Era*. Naval Institute Press, Annapolis, Maryland.

Ware, Chris

1992 Fireships and Bomb Vessels. In *The Line of Battle: The Sailing Warship, 1650-1840*, edited by Brian Lavery, pp. 85-97. Conway's History of the Ship Series. Conway Maritime Press, London.